

**DIVISION VI
INDIVIDUAL GRINDER PUMP INSTALLATIONS**

VI-1.000 DESCRIPTION

1.010 General

- A. Any extension of the Kitsap County sanitary sewer extension shall be completed in accordance with the applicable requirements of the Standards for Sanitary Sewer Extensions, Division I, Section I-4.000, Forms and Agreements. Together with submittal of the individual sewage pump installation plans for approval, the property owner shall also submit a signed copy of the “Sewage Pump Installation, Operation, and Maintenance Agreement” together with the current recording fee.
- B. The station’s operational components shall be locate at an elevation that is not subjected to the 100 year frequency storm flood and associated wave action, or shall be otherwise adequately protected as certified by a professional engineer registered in the State of Washington.

1.020 Individual Grinder Pump Stations

- A. Only one grinder pump station is allowed per residence. It will be the responsibility of the homeowner to maintain the grinder station and the forcemain on their property. Areas with up to 10 homes (without further possibility of expanding) shall be served by individual grinder pump stations and shall be reviewed and approved by Kitsap County on a case by case basis. Developments with more than 10 homes will use a commercial pump station maintained by the County.
- B. It will be the property owner’s responsibility to obtain preliminary approval of the concept for their particular situation. Upon preliminary approval, the property owner will be required to submit an engineered plan of the proposed installation showing all pertinent information together with specifications of all materials to be used.

VI-2.000 MATERIAL AND CONSTRUCTION

2.010 General

- A. The developer shall submit information from the material manufacturer or fabricator showing that the materials meet the requirements of the design and pertinent specifications. The developer shall provide submittals to the County on all materials to be used.

2.020 Pump Station

- A. The individual sewage pump installation shall consist of a single two horsepower grinder pump, tank, and system controls, valves and piping.
- B. The grinder pump shall be two horsepower grinder pump designed to grind solids normally contained in domestic and commercial wastes. A pump curve indicating the pump capacity at design head for the pump to be installed shall be included with submittal.
- C. Tanks shall be either fiberglass, steel with protective coating for underground installations, or concrete meeting the dimensions shown on the standard plan. Tanks shall be watertight.

2.030 Piping and Control Facilities

- A. System controls shall consist of a higher water alarm light, one circuit breaker per pump, 120V AC control voltage transformer, starters, NEMA 3R enclosure for electrical control circuits which shall be mounted on the building adjacent to the pump unit, three liquid level control floats (pump off, pump on, high water alarm) and necessary wiring and appurtenances for a complete installation.
- B. The service piping from the pump unit to the county pressure main shall be a minimum of 1 ¼ inch diameter schedule 80 PVC. A minimum burial depth of 24 inches shall be maintained.
- C. Where a gravity sewer main exists in the public right-of-way, building sewer pressure lines shall discharge into gravity side sewers at the property/easement line as per County Standard Detail.

VI-3.000 INSTALLATION

3.010 General

- A. A check valve and a gate valve shall be provided inside the tank with a union or quick disconnect fitting provided for easy removal of the pump. An appropriate size saddle shall be provided where the service line connects to the county pressure main and shall be provided with a corporation stop, check valve and valve box installed over the corporation stop as shown on the County Standard Details.

- B. No individual sewage pump shall be installed on the discharge side of an existing septic tank. Pumping units shall be connected directly to the building sewer line.

VI-4.000 TESTING

4.010 General

- A. The completed grinder pump station shall be given an operational test of all equipment for leaks in all piping and seals, and for correct operation of the automatic control system and all auxiliary equipment. Developer shall conduct preliminary tests and be assured that the section to be tested is in an acceptable condition before requesting the County to witness the test.

- B. Only after final testing and acceptance by the County is the grinder pump station allowed pumping sanitary sewage into the County system.

Senior Program Manager, PW/WW



KITSAP COUNTY PUBLIC WORKS WASTEWATER DIVISION

Sewage Pump Installation, Operation, and Maintenance Agreement

WHEREAS, _____, hereinafter known as the "OWNER", does enter into an agreement with KITSAP COUNTY, hereinafter known as the "COUNTY", on this ____ day of _____, _____, for the project known as the _____ INDIVIDUAL PUMP SYSTEM.

WHEREAS, Owner is possessed of certain real property located at the following address, and legally described as follows:

Qtr: _____ Qtr: _____ Section: _____ Township: _____ Range: _____

Plat or Short Plat: _____ Tax Parcel No.: _____

and is within the area served by Kitsap County sewer system, and,

WHEREAS, the sewer trunk line is at an elevation adjacent to the real property of Owner that it cannot be served by gravity and necessitates the use of a sewer pump, and

WHEREAS, Owner agrees with the County to install an approved pump according to specifications of the County and to keep and maintain said pump and associated equipment in good working order. In the event repairs and maintenance of said pump and associated equipment is required of the County for any reason whatever not the fault of the County, the reasonable cost of said work shall be charged back against the Owner and may become a lien upon said real property.

The parties understand the foregoing, and do now therefore AGREE:

1. That Owner shall furnish and install approved sewer pump and associated equipment according to specifications and subject to installation approval of the County.

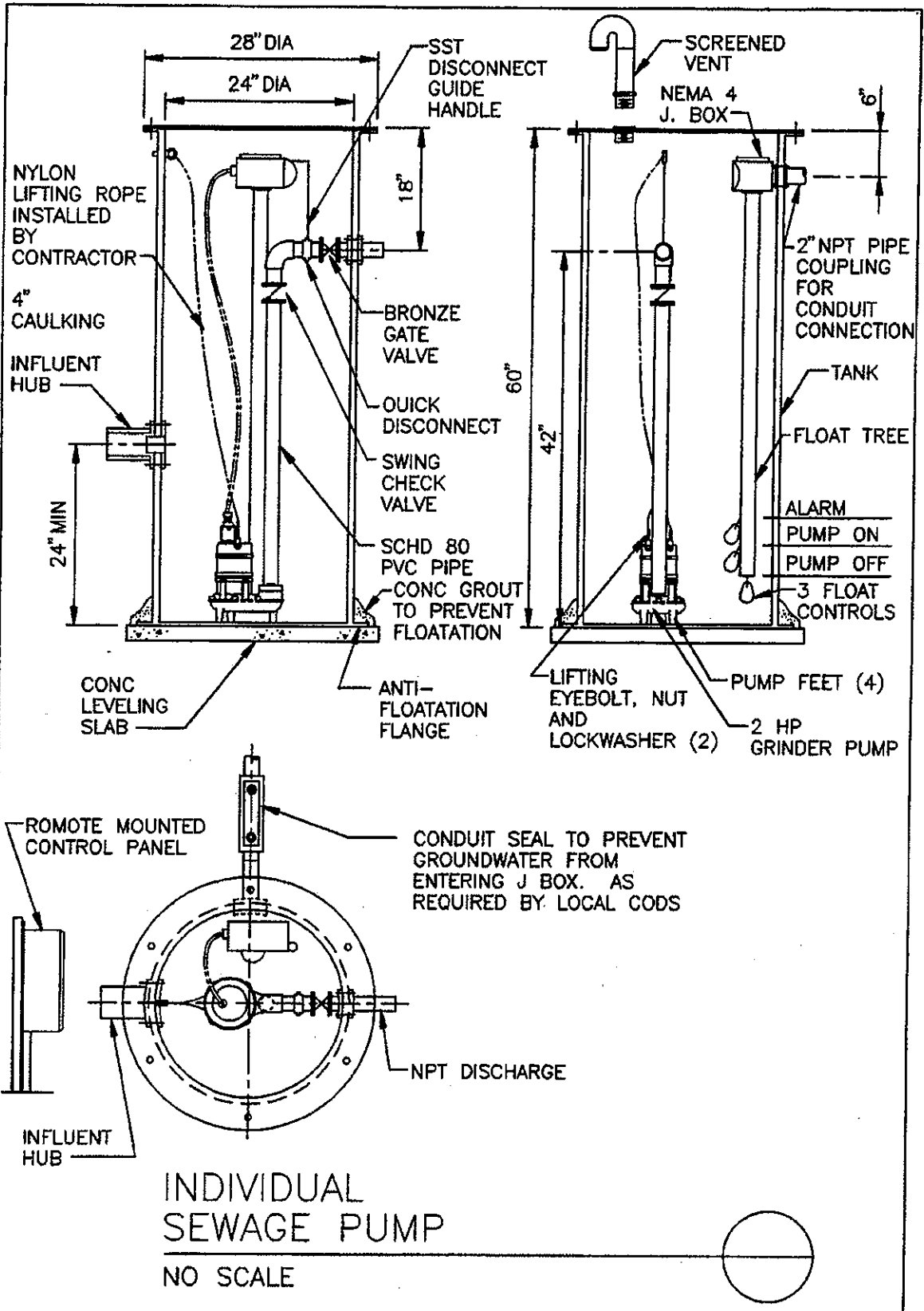

2585003/KCPW4 12.95

INDIVIDUAL SEWAGE PUMP
NO SCALE

<p>KITSAP COUNTY Dept. of Public Works</p>	<p>INDIVIDUAL SEWAGE PUMP</p>	<p>DETAIL PS-1</p>
--	-----------------------------------	------------------------

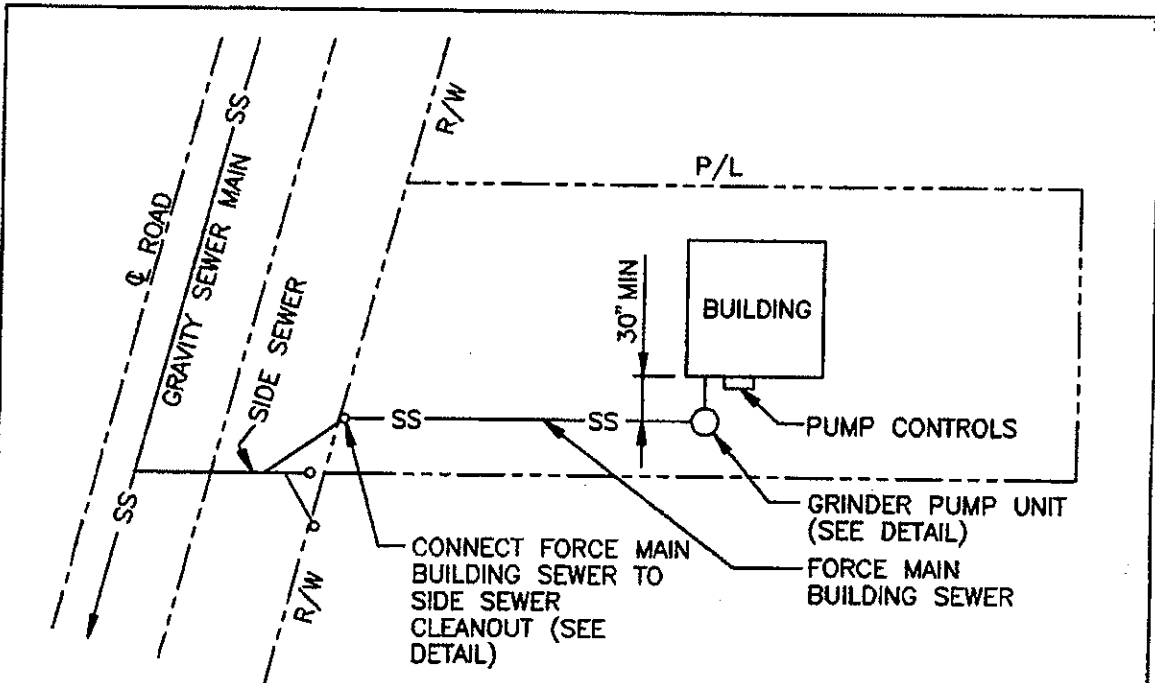

TYPICAL SITE PLAN
NO SCALE

PUMP REQUIREMENTS

STATIC HEAD _____ FT.	RECOMMENDED PUMP: TYPE - <u>GRINDER PUMP</u>
DYNAMIC HEAD _____ FT. @ _____ GPM	HP - <u>2 HORSE POWER</u>
TOTAL HEAD _____ FT	MODEL - _____
DISCHARGE VELOCITY _____ FPS	MFGR. - _____
POWER REQUIREMENTS _____ V, _____ ϕ	SUPPLIER - _____
	FLOW @ HEAD - _____ GPM @ _____ FT

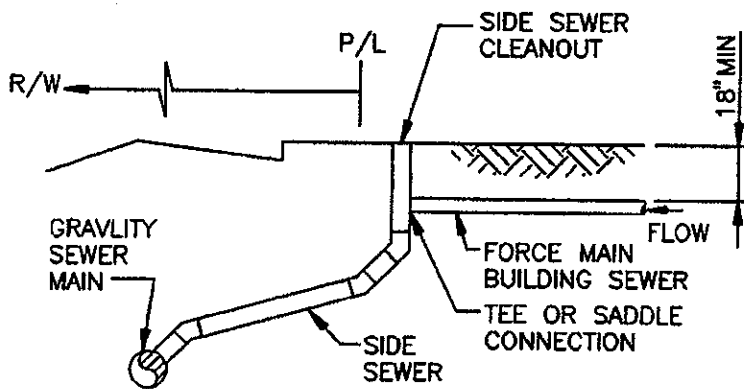

SEWER CONNECTION
NO SCALE

2585003/KCP#2 12.95

<p>KITSAP COUNTY Dept. of Public Works</p>	<p>INDIVIDUAL PUMP INSTALLATION A</p>	<p>DETAIL PD-10</p>
--	---	-------------------------

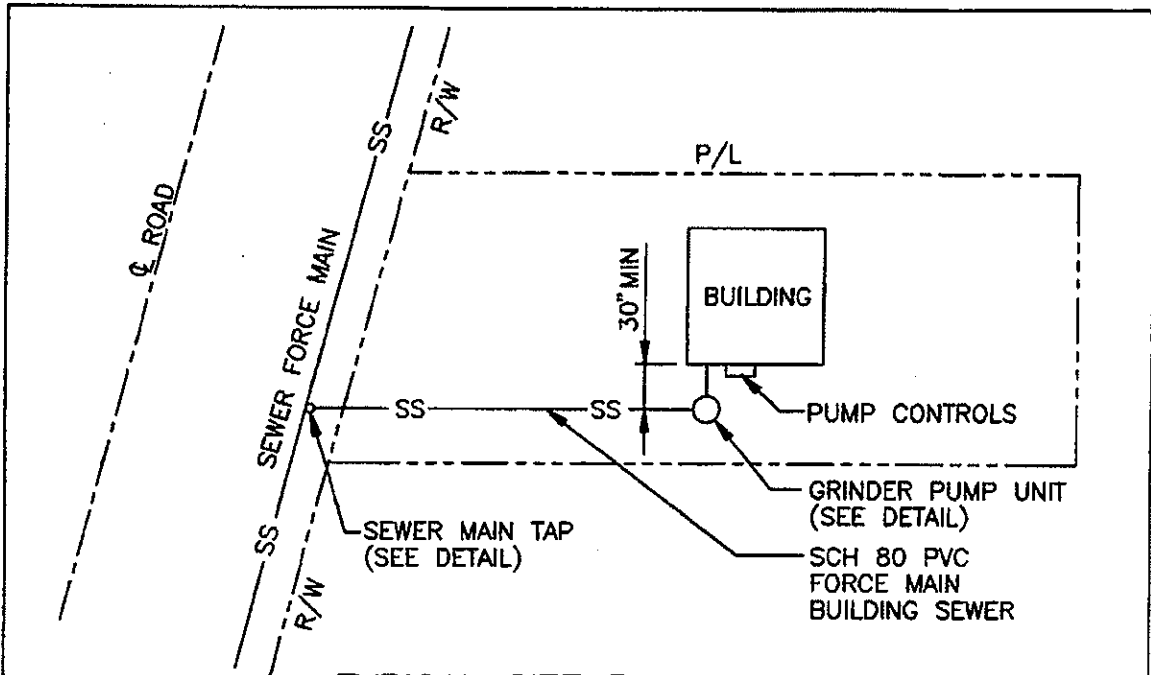

TYPICAL SITE PLAN
NO SCALE

PUMP REQUIREMENTS

STATIC HEAD _____ FT.	RECOMMENDED PUMP: TYPE - <u>GRINDER PUMP</u>
DYNAMIC HEAD _____ FT. @ _____ GPM	HP - <u>2 HORSE POWER</u>
TOTAL HEAD _____ FT	MODEL - _____
DISCHARGE VELOCITY _____ FPS	MFGR. - _____
POWER REQUIREMENTS _____ V, _____ ϕ	SUPPLIER - _____
	FLOW @ HEAD - _____ GPM @ _____ FT

SADDLE, ROMAC
STYLE 304
OR EQUAL

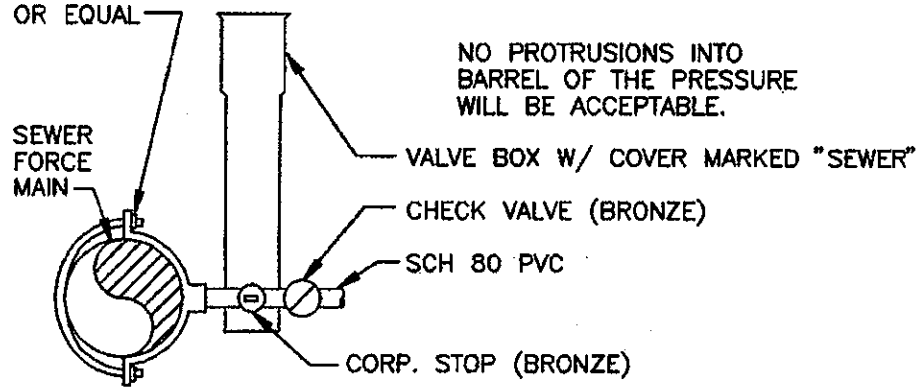

NO PROTRUSIONS INTO
BARREL OF THE PRESSURE
WILL BE ACCEPTABLE.

FORCE MAIN CONNECTION
NO SCALE

2585003/KCPW2 12.85

KITSAP COUNTY Dept. of Public Works	INDIVIDUAL PUMP INSTALLATION B	DETAIL PD-11
--	-----------------------------------	-----------------