

# Prescriptive Flow Control Design Criteria

## Kitsap County Code Title 12.20.035

Individual downspout infiltration systems are trench infiltration systems designed to receive stormwater from roof downspout drains. The following design criteria are intended to guide the applicant in providing an acceptable plan per Kitsap County Code.

1. Prior to approval of an individual downspout infiltration system, a site plan, drawn to scale, shall be submitted showing the location of the proposed infiltration system together with adjacent building structures, wells, septic drainfields and tanks, curtain drains and property lines.
2. All trenches shall be a minimum of 5 feet from any property line, 10 feet from any structure, 30 feet downslope or 100 feet upslope from any septic drainfield, 15 feet downslope or 50 feet upslope from any septic tank, 10 feet downslope or 30 feet upslope of any curtain drain, 50 feet from private wells and 100 feet from public wells. Greater setbacks may be required by the Bremerton Kitsap County Health District or the Director.
3. All trenches shall be a minimum of 200 feet from any slope steeper than 30%. This distance may be reduced based on a geotechnical engineering report.
4. There is no minimum spacing between trench center lines and no maximum trench width. However, flow distribution lines shall be installed at a maximum spacing of 10 feet or less between pipes.
5. Trench length shall not exceed 100 feet from the inlet sump.
6. A minimum of one soil log shall be obtained for each proposed individual downspout infiltration system. The soil log shall extend a minimum of 18" below the bottom of the trench, describe the USDA textural class of the soil horizon through the depth of the log, and note any evidence of high groundwater level, such as mottling.
7. Trench bottoms shall be a minimum of 12 inches above seasonal high ground water or relatively impervious layer.
8. Geotextile filter fabric shall be placed on top of the drain rock prior to backfilling.
9. A catch basin inlet sump (Type I or Type 30) shall be located upstream of the trench, which provides a minimum of 24" of depth below the invert of the outlet pipe. The outlet tee shall be designed so as to be submerged at all times, and a screening material shall be installed on the pipe outlet.
10. An overflow device is required for all downspout infiltration systems. In situations where the elevation difference between the bottom of the downspouts and the top of the infiltration bed is less than 3 feet, the overflow device may be as simple as an elbow on the downspout pipe. Where elevation differences exceed 3 feet, the overflow must be placed at the observation well or catch basin near the bed itself. Alternatively, the overflow device may be deleted if the washed gravel is extended to the ground surface, allowing runoff to flow out the top of the event of overflow.
11. An observation well is recommended, but not required. The observation well allows the homeowner to monitor the performance of the facility.

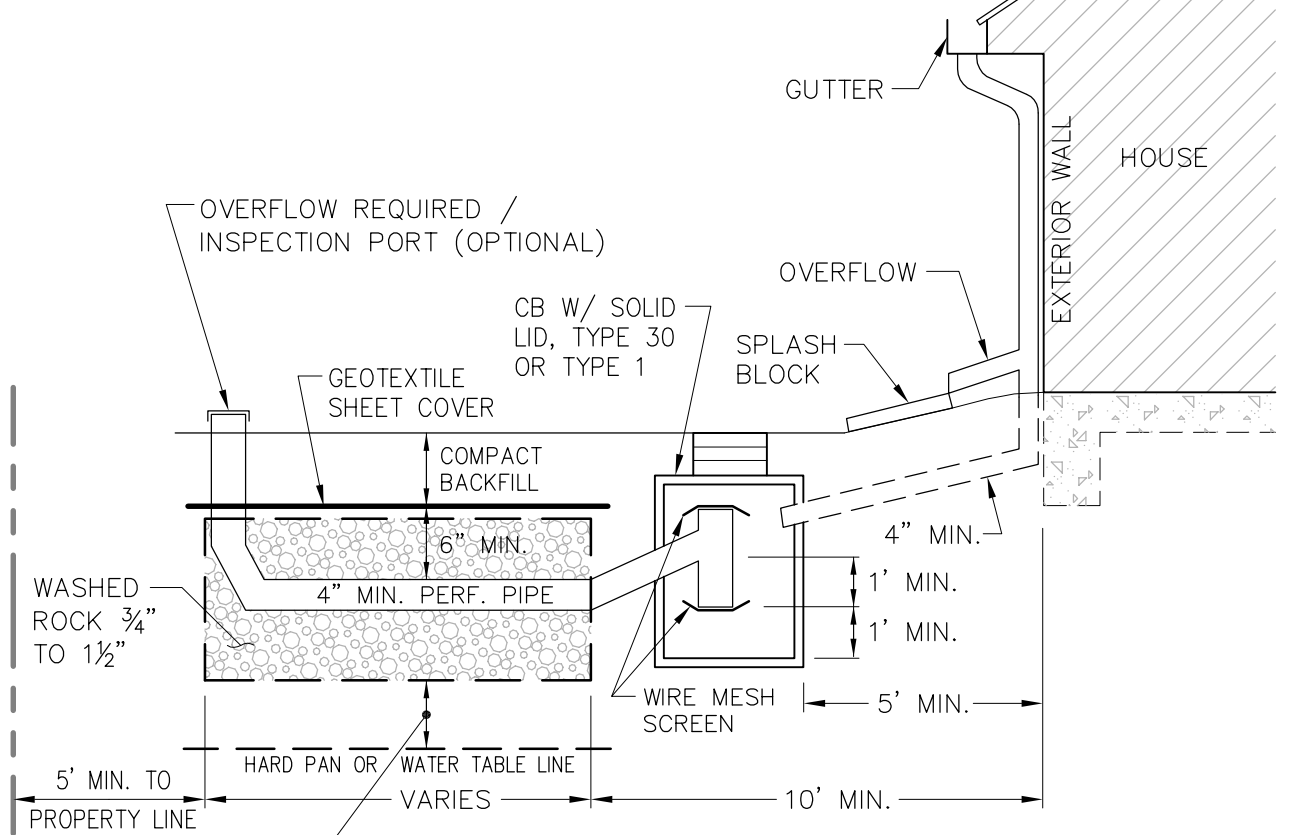
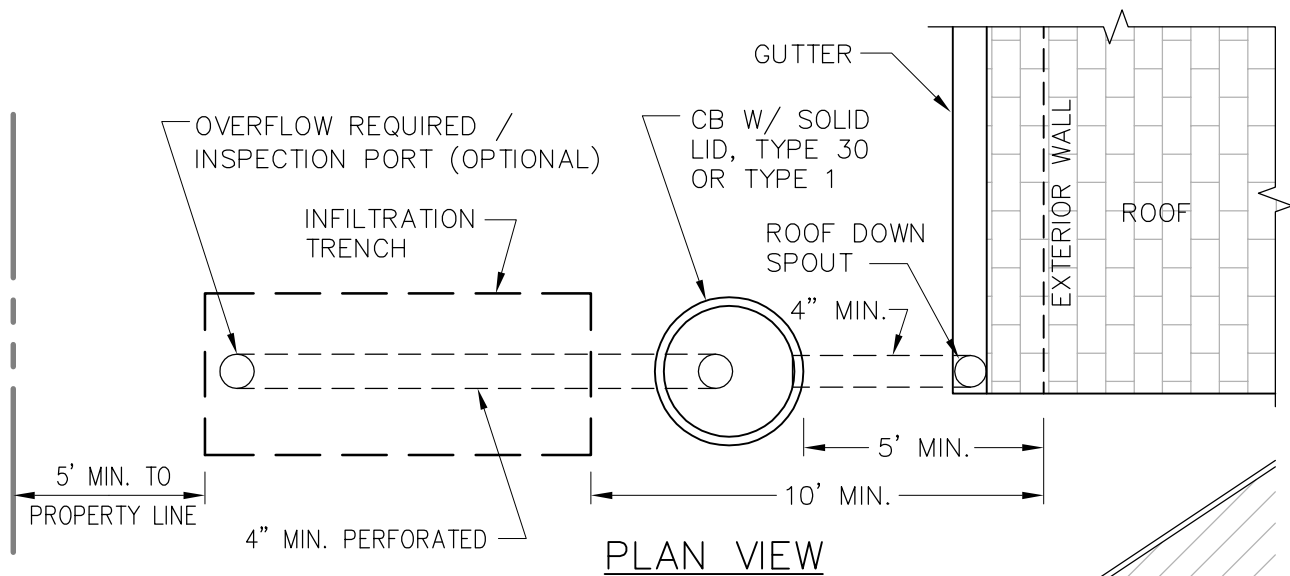

12" MIN. SEPARATION FROM BOTTOM OF PIT TO HARD PAN OR WATER TABLE LINE

## DOWNSPOUT & INFILTRATION DETAIL

NTS



KITSAP COUNTY  
 DEPT. OF PUBLIC WORKS  
 614 DIVISION STREET  
 MS-26 PORT ORCHARD,  
 WA 98366  
 TEL: (360) 337-5777 FAX: (360) 337-4867

### PRESCRIPTIVE FLOW CONTROL, DOWNSPOUT, & INFILTRATION DETAIL

Date: 10/27/08

LOCATION: G:\Engineer\Acad2000\Details\Storm\DwnSpout.dwg