



# #92—ACCESSIBLE PARKING

This handout describes general requirements. For complete code requirements, see Washington State Building Code Chapter 11.

## General Requirements

Accessible car and van parking spaces shall comply with ICC/ANSI A117.1, Section 502.

## Vehicle Space Size

Car parking spaces shall be 96 inches minimum in width.  
Van parking spaces shall be 132 inches minimum in width.



## Vehicle Space Marking

Car and van parking spaces shall be marked to define the width. Where parking spaces are marked with lines, the width measurements of parking spaces and adjacent access aisles shall

be made from the centerline of the markings.

Figure 1: Vehicle Parking Space Size

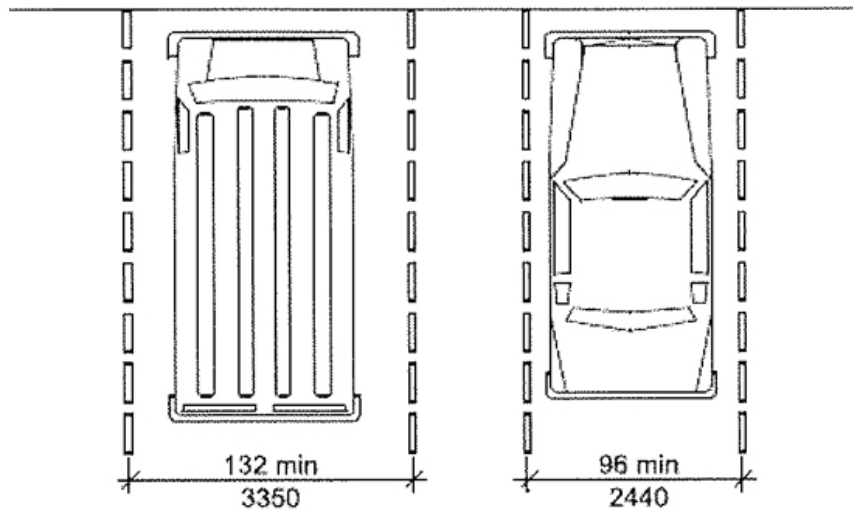

### Access Aisle

Car and van parking spaces shall have an adjacent access aisle complying with ICC/ANSI A117.1, Section 502.4.

### Access Aisle Location

Access aisles shall adjoin an accessible route. Two parking spaces shall be permitted to share a common access aisle. Access aisles shall not overlap with the vehicular way. Parking Spaces shall be permitted to have access aisles placed on either side of the car or van parking space. Van parking spaces that are angled shall have access aisles located on the passenger side of the parking space.

### Access Aisle Width

Access aisles serving car and van parking spaces shall be 60 inches minimum in width.

### Access Aisle Length

Access aisles shall extend the full length of the parking spaces they serve.

### Access Aisle Marking

Access aisles shall be marked so as to discourage parking in them. Where access aisles are marked with lines, the width measurements of access aisles and adjacent parking spaces shall be made from the centerline of the markings.

Figure 2: Parking Space Access Aisle

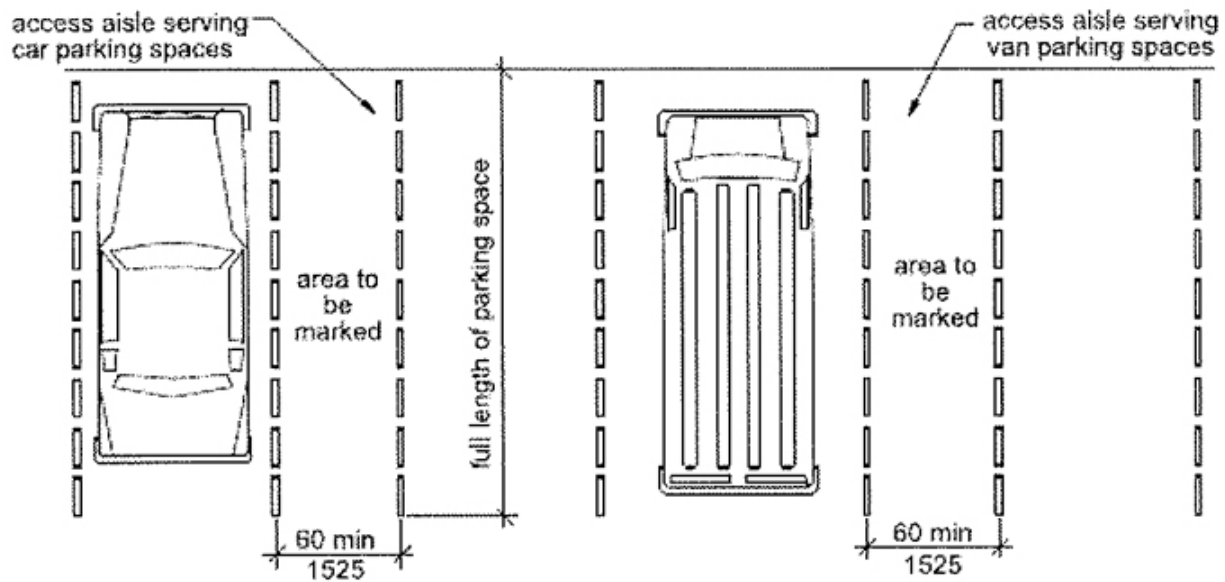

## Passenger Loading Zones

### General

Accessible passenger loading zones shall comply with ICC/ANSI A-117.1, Section 503.

### Vehicle Pull-up Space Size

Passenger loading zones shall provide a vehicular pull-up space 96 inches minimum in width and 20 feet minimum in length.

### Access Aisle

Passenger loading zones shall have an adjacent access aisle complying with Section 503.3.

### Location

Access aisles shall adjoin an accessible route. Access aisles shall not overlap the vehicular way.

### Width

Access aisles serving vehicle pull-up spaces shall be 60 inches minimum in width.

### Length

Access aisles shall be 20 feet minimum in length.

### Marking

Access aisles shall be marked so as to discourage parking in them.

### Floor Surfaces

Vehicle pull-up spaces and access serving them shall have slopes not steeper than 1:48. Access aisles shall be at the same level as the vehicle pull-up space they serve.

### Vertical Clearance

A vertical route from an entrance to the passenger loading zone shall provide a vertical clearance of 114 inches minimum.

Figure 3: Passenger Loading Zone Access Aisle

