



#83—WOODSTOVES AND FIREPLACES

Required Permits

A Mechanical Permit is required for the installation of all wood- and solid-fuel-burning appliances including all wood stoves, manufactured fireplaces, fireplace inserts, or any other solid-fuel-burning appliance. A wood-burning appliance or fireplace installed without a permit or inspections is a code violation and may invalidate your fire insurance policy.

Mobile Home Installation

If a wood-burning appliance is to be installed in a manufactured home, it MUST be specifically listed for installation in a manufactured home. An Alteration/Installation Permit must be obtained from the Washington State Department of Labor and Industries Mobile Home Division (360-415-4000).

Certified Appliances

All wood stoves and solid-fuel-burning appliances installed in Washington State and Kitsap County shall be certified by the United States Environmental Protection Agency (EPA). All certified appliances can be identified by a tag or plate (typically located on the back of the appliance) indicating compliance with the EPA Particulate Emission Standards. For example, see Figure 1. It is illegal to install an uncertified wood stove or insert in Washington State. It is also illegal to sell, give away or exchange an uncertified woodstove unless for scrap.

Figure 1.

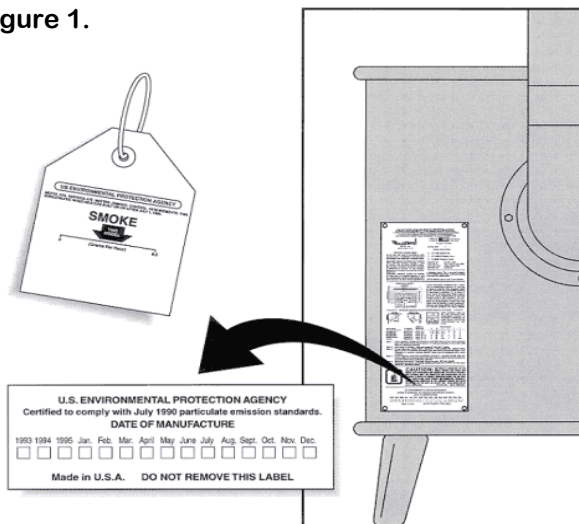

Listed Appliances

In addition to being certified, the International Mechanical Code (IMC) requires that all appliances be “listed” by Underwriters Laboratory (UL), International Code Council (ICC), or any other nationally recognized testing agency.

Wood-burning appliances tested by these agencies have been tested under extreme conditions and are approved for installation with specifications for distances to combustible materials. These specified distances are related to the actual tested heat radiation capabilities of the unit. All woodstoves, fireplaces and other mechanical equipment shall be installed in full accordance with its listing and the manufacturer’s installation instructions.

General Installation Requirements

No wood stove or fireplace shall be permitted for use as the sole source of heat in any new or remodeled structure or dwelling.

In accordance with the Washington State Ventilation and Indoor Air Quality Code (VIAQC) Section 402.2, solid-fuel-burning appliances must be provided with the following:

- Tight-fitting metal or ceramic glass doors;
- A source of primary combustion air from outside the structure, connected to the appliance as per manufacturer's specification;
- The air inlet shall originate at a point below the firebox; and
- The duct shall be 4" or more in diameter, may not exceed 20' in length, and must be installed according to manufacturer's instructions.

In accordance with the VIAQC Section 402.3, fireplaces must be provided with each of the following:

- Tightly fitting flue dampers operated by a readily accessible manual or approved automatic control. Exception: Fireplaces with gas logs shall be installed in accordance with the International Mechanical Code (IMC) and the International Fuel-Gas Code (IFGC).

- An outside source for combustion air ducted into the firebox. The duct shall be at least 6 square inches, and shall be provided with an operable outside air duct damper.
- Site-built fireplaces shall have tight-fitting glass or metal doors, or an approved mechanical system to minimize backdrafting. Factory-built fireplaces shall use doors listed for the installed appliance.
- If these conditions are not met, the appliance and the manufacturer's recommended combustion air supply, as an installed unit, shall be certified by an independent testing laboratory to have passed Test No. 11 – Negative Pressure Test, Section 12.3, of Underwriter's Laboratory of Canada 5627-M1984 "Space Heaters for Use with Solid Fuels," Modified per VIAQC Section 402.2.

Exception: Combustion air may be supplied to the room in which the solid-fuel-burning appliance is located, rather than using direct ducting, provided that one of the following conditions is met:

- The solid-fuel-burning appliance is part of a central heating plant and is installed in an unconditioned space in conformance with the International Mechanical Code.
- The solid-fuel-burning appliance is installed in existing construction directly on a concrete floor or surrounded by masonry materials as in a fireplace.

Chimneys

Chimneys shall be constructed of masonry in accordance with the Kitsap County Building & Fire Code requirements, or shall be approved, factory-built assemblies listed or approved by UL, ICC or another recognized agency for use with wood-burning- or other solid-fuel-burning appliances. The listed or approved chimney assemblies shall be installed in accordance with their listings. The required clearance from the chimney to combustibles will be indicated on each section of chimney. The minimum clearance for a masonry chimney is 2" to any combustible material.

Note: Metal liners installed within masonry chimneys or relined chimneys shall be of approved listed materials and installed in accordance with the listing.

Chimney Height Termination

The chimney shall terminate at a point not less than 2' above any portion of a structure within a 10' radius of the chimney.

Multiple Venting

Venting of more than one appliance into a single chimney flue is not a recommended procedure. However, the code does allow multiple venting provided that the following requirements are complied with:

- Inlets are offset so that no portion of an inlet is opposite any other inlet.
- Flue size is at least equal to the size of the largest vent connector plus 50% of the area of the second.
- The appliances are located within the same story of the building.
- Any gas-burning appliance is vented above the other appliance.

Existing Fireplaces and Chimneys

There are acceptable methods of connecting a wood-burning or other solid-fuel-burning appliance to a masonry fireplace. However, it is never permissible to simply seal off the front of the firebox and run a vent connector into the firebox, terminating it there. See the example of an approved connection at Figure 2.

Note: Wood stoves may be connected to existing metal fireplace chimneys **only** if the listing for that specific chimney allows it (most do not).

Hearth and Floor Coverings

The hearth slab shall extend at least 16" in front of the opening side of the appliance. Floor protection shall extend 8" beyond the sides and rear of the appliance.

In all cases, the floor area directly beneath the appliance shall be protected and the minimum clearance from the bottom of the appliance to the floor protection shall be 6" unless a lesser clearance is specified for a listed appliance.

The hearth slab and floor protection shall consist of not less than 3/8" thick asbestos, concrete, hollow metal, stone, tile or other approved noncombustible materials. Combustible floor coverings shall not encroach into the required hearth area.

Required Inspections

All wood-burning appliances require at least one inspection to assure that it is installed in accordance with the listing requirements and the manufacturer's installation instructions. Upon inspection, all manufacturer's installation instructions shall be with the installed unit and available to the Building Inspector.

Figure 2. Connection to an Existing Chimney

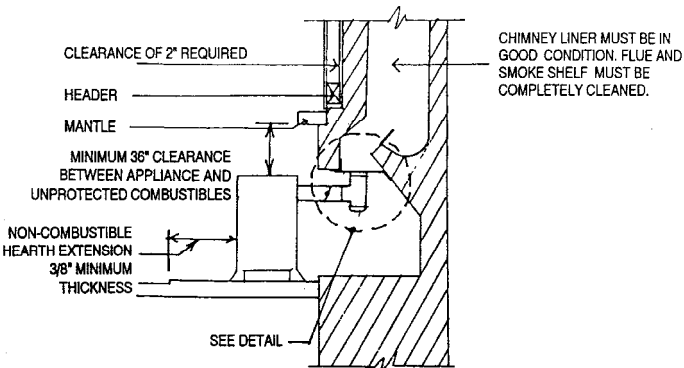
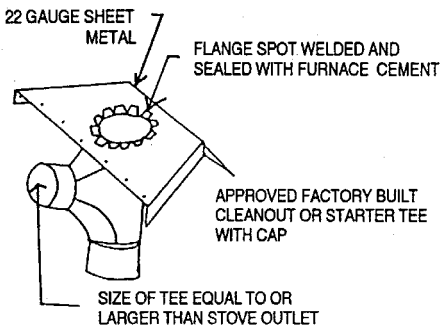
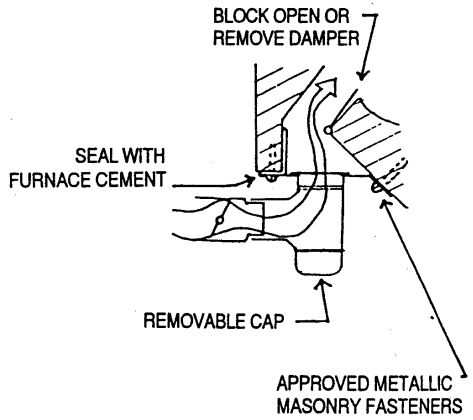

Typical Woodstove Installation

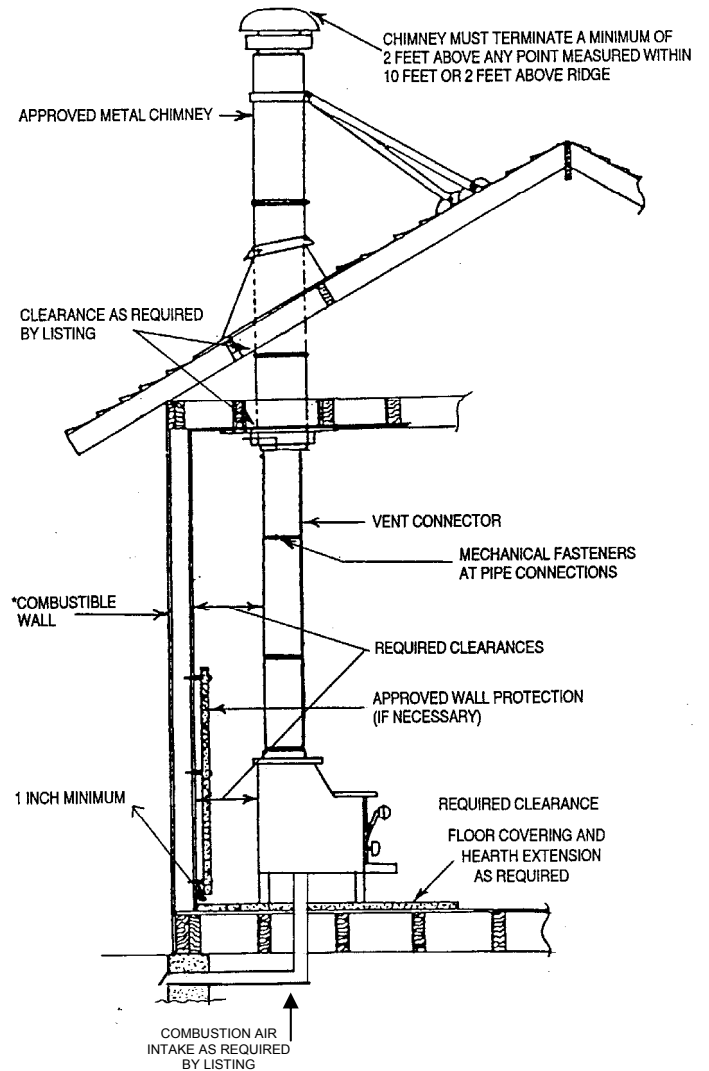

Wood-burning Responsibilities in Washington State

1. You must observe burn bans—do not use a fireplace or existing uncertified woodstove during a burn ban unless it is the only source of heat.
2. You can burn only manufactured logs or wood seasoned at least one year.
3. You cannot burn plastic, foil or any other garbage.
4. You must operate your woodstove or fireplace correctly in accordance with its listing.
5. You must maintain your wood stove or fireplace in good safe working order.